



# 2000 Series

T24PE Indicator



Ph 0800 27 26 26

info@ansutek.co.nz  
www.ansutek.co.nz  
www.ansutekbiz.co.nz



## *Designed for Dependability and Durability at a Practical Price!*

The OHAUS Defender 2000 indicators offer OHAUS' signature accuracy for commercial and industrial weighing applications at an unbeatable price. Depend on the OHAUS Defender 2000 Series when you need accuracy you can count on while maximizing your budget.

### *Standard Features Include:*

- **Enhanced Functionality Beyond Standard Weighing Provides Operation for Additional Applications**—In addition to standard weighing mode, this economical indicator also features parts counting and accumulation functions.
- **Easy-to-Read Red LED Display Can Be Viewed in Even the Dimmest Industrial Conditions**—Defender 2000 indicator's red LED indicator clearly displays results that can be seen in locations with less than optimal lighting.
- **Versatile Power Capabilities Provide Unrestricted Operation Wherever Your Weighing Needs Are**—An AC adapter and internal rechargeable lead acid battery provide options for powering your Defender 2000 indicator.

# 2000 Series T24PE Indicator

Model	T24PE
Capacity	Up to 20000 kg
Maximum Displayed Resolution	1:20000
Weighing Units	kg, g, lb
Application Modes	Weighing, Parts Counting, Accumulation
Construction	ABS plastic housing
Display	6-digit, 7-segment red LED, 20 mm high digits
Keyboard	4 function mechanical keys, raised, tactile
Load Cell Excitation Voltage	3 VDC
Load Cell Drive	Up to 4 × 350 ohm load cells
Load Cell Input Sensitivity	Up to 3 mV/V
Zero Range	2% or 100% of full scale capacity
Tare Range	Full capacity by subtraction
Stabilization Time	1 second
Auto-Zero Tracking	Off, 0.5, 1 or 3 divisions
Power	AC adapter with internal rechargeable lead acid battery
Battery Life	80 hours continuous use with 12 hour recharge time
Interface	Optional RS232
Operating Temperature Range	-10°C to 40°C
Housing dimensions (W × D × H)	210 × 168 × 80 mm
Net weight	1.4 kg
Shipping weight	2.4 kg
Shipping Dimensions (W × D × H)	272 × 235 × 175 mm

## Other Standard Features and Equipment

ABS plastic housing, red LED display, tactile mechanical keys, optional RS232C with manual/continuous/interval printing, hardware configuration lockout switch, internal lead-acid rechargeable battery and AC adapter. Software included for parts counting mode with selectable sample sizes and weighing totalization (Accumulation) functions. Selectable span calibration points

## Compliance

- **Product Safety:** IEC/EN 61010-1
- **Electromagnetic Compatibility:** IEC/EN 61326-1 Class B, Basic environments

## Accessories

RS232 Kit .....	30101019
SF40A Impact Printer .....	30045641
In-Use-Cover .....	30101017
Column Adapter Kit .....	30101020
Column 500 mm, SS .....	30101022
Column 700 mm, SS .....	30101025
Column 1000mm, SS .....	30101024
Auxiliary display, AD7-RS .....	30472064

## Dimensions

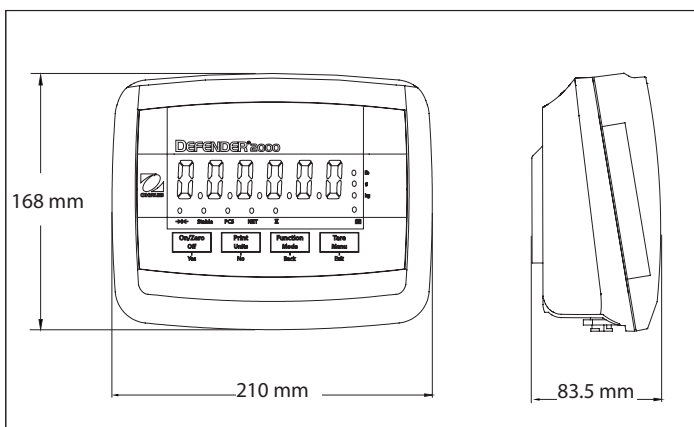

info@ansutek.co.nz  
www.ansutek.co.nz  
www.ansutekbiz.co.nz

**\*ISO 9001:2008**  
Registered Quality  
Management System  
30248465

80774825 © Copyright OHAUS Corporation

